

ODKLEJACZE GAZOWE DO TŁOCZNIKÓW

NITROGEN GAS EJECTORS FOR DIES

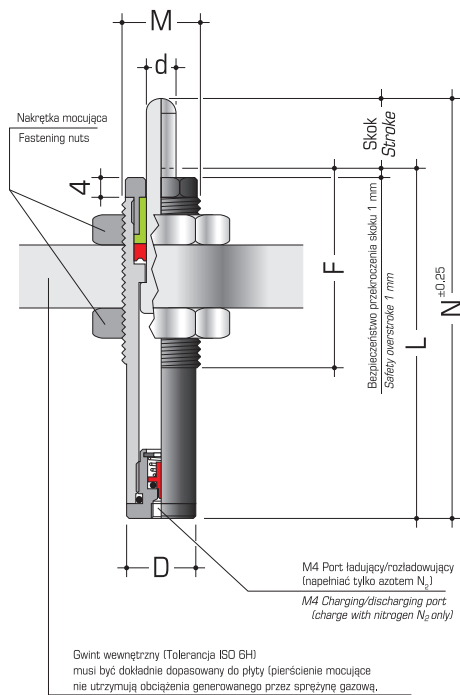
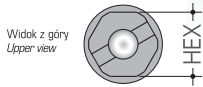

EG

Odklejacze EG napełnione są azotem. Dostępne z minimalnym ciśnieniem 20 bar do ciśnienia maksymalnego 150 bar z odpowiednimi siłami załączonymi w tabelce. Na życzenie można zamówić każdą pośrednią siłę i otrzymać odklejacze gotowe do użycia.

The EG lifters are charged with nitrogen gas. The charging pressure can be from the minimum of 20 bar to the maximum of 150 bar, with the corresponding forces shown in the table. Any intermediate force can be requested with the order; thus receiving them charged and ready-to-use.

JAK ZAMÓWIĆ

8 szt. EG16-10 42daN

8 szt. odklejaczy gazowych EG z gwintowanym cylindrem M16 x 1.5, skok 10 mm, siła początkowa 42 daN

HOW TO ORDER

Nº 8 EG16-10 42daN

Nº 8 nitrogen gas ejectors series EG with threaded body M16 x 1.5, stroke length = 10 mm, initial force = 42 daN.

UWAGI TECHNICZNE

Ważne: instrukcja obsługi oraz maksymalna ilość skoków na minutę na stronie C8-C15.

TECHNICAL NOTES

Important use instructions and maximum number of cycles per minute on pages C8-C15.

(*²) Siła końcowa (siła przy pełnym skoku) = Siła początkowa × R (*²) Final force (force at full stroke) = Initial force × R

MODEL MODEL	L mm	N mm	d mm	F mm	D mm	M	HEX mm	daN 20bar 150bar	R (* ²)	
EG16-10	70	80							1.1	
20	80	100							1.3	
30	90	120							1.3	
40	100	140							1.4	
50	110	160	6	40	14	M16x1.5	13	6	42	1.5
60	120	180							1.7	
70	130	200							1.8	
80	140	220							1.9	
100	160	260							2.0	
EG24-10	70	80							1.2	
20	80	100							1.4	
30	90	120							1.5	
40	100	140							1.5	
50	110	160	12	45	22	M24x1.5	19	23	170	1.6
60	120	180							2.0	
70	130	200							2.0	
80	140	220							2.2	
100	160	260							2.4	

Możliwe mocowania

(zobacz także

Akcesoria do sprężyn gazowych str. E1)

Fixing possibilities

(see also "Accessories for nitrogen gas springs for dies" on page E1)



Nakrętki mocujące / Fastening nuts

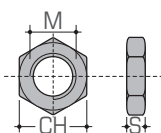

MODEL MODEL	M mm	S mm	CH mm
EG-D-16	M16 x 1.5	8	24
EG-D-24	M24 x 1.5	10	36

Specjalny klucz / Special key



MODEL MODEL	DLA FOR
EG-CH-16	EG16
EG-CH-24	EG24