

FBC/FBSMLX

Mocujące płyty bazowe / Fixing base plate



Standardowe stalowe elementy do mocowania sprężyn gazowych: płyty mocujące dla modeli CSX, SMLX, CX, CSMX, TOP, CHT, CSMHT, CRAL.

Standard steel elements for nitrogen gas springs fixing: base plates for models CSX, SMLX, CX, CSMX, TOP, CHT, CSMHT, CRAL.

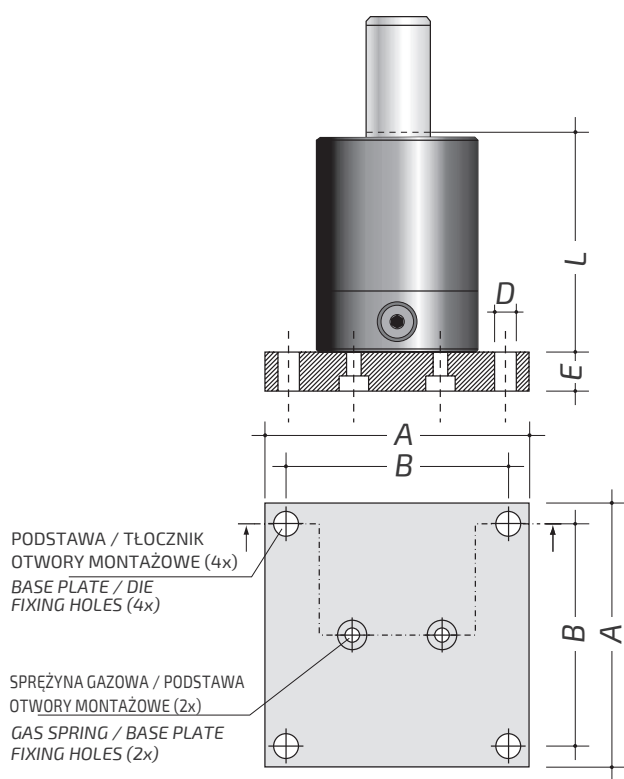

RYS. 1
FIG. 1

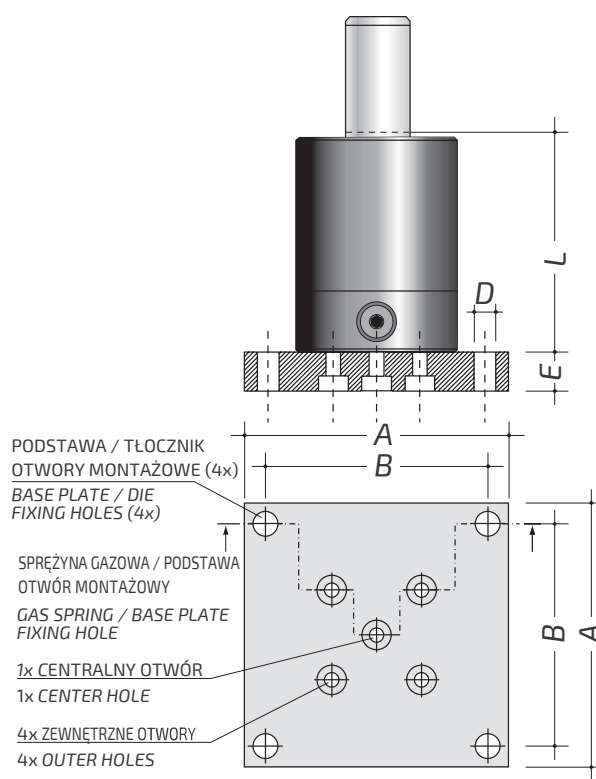

RYS. 2
FIG. 2

Model Model	A mm	B mm	Ø D mm	E mm	Zewnętrzne otwory Outer holes	Do modeli... For models...	Otwór centralny Center hole	Do modeli... For models...	RYS. Fig.
FBC 50	70	50	9	16	-	CSX50, CX50, CSMX50, TOP50, CHT50, CSMHT50, CRAL50	-	-	1
63	90	68	11	20	-	CSX63, CX63, CSMX63, TOP63, CHT63, CSMHT63, CRAL63	-	-	1
75	90	68	11	20	TAK / YES	CSX75, CX75, CSMX75, TOP75, CHT75, CSMHT75, CRAL75	TAK / YES	SMLX75	2
95	110	90	11	20	TAK / YES	CSX95, CX95, CSMX95, TOP95, CHT95, CSMHT95, CRAL95	TAK / YES	SMLX95	2
120	125	100	11	20	TAK / YES	CX120, CSMX120, TOP120, CHT120, CSMHT120, CRAL120	NIE / NO	-	2
FBSMLX 50	70	50	9	16	NIE / NO	-	TAK / YES	SMLX50	2
63	90	68	11	20	NIE / NO	-	TAK / YES	SMLX63	2