

SUWAKI DODATKOWA SPECYFIKACJA

CAM UNITS ADDITIONAL SPECIFICATION TABLE

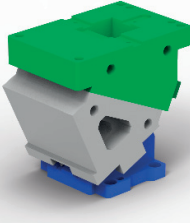

Typ Type	Symbol: Catalog No:	Powierzchnia Montażowa Mounting Face		Kąt Pracy Working Angle	Skok Suwaka Cam Stroke	Siła Robocza Working Force (kN/tonf)		Wysokość Zamknięcia Shut Height	Siła Sprężyny Gazowej Gas Spring Force (N)		Tylna przestrzeń do usunienia Rear Removal Space L (mm)	Waga Weight (kg)	Sprężyna Gazowa Gas Spring (Special Spring)		
		Szerokość Width	Wysokość Height			Skoki Strokes 1.000.000	Skoki Strokes 300.000		Siła końcowa Final load	Siła powrotu Return force					
	K801-04-200	200	150	0°	35,4	139,8	164,5	300	13914	18686	-	89	RV1000-063-B		
	K801-06-200					197,4	230,3								
	K801-04-200			5°	39,0	139,8	164,5			18653					
	K801-06-200					197,4	230,3								
	K801-04-200			10°	42,8	139,8	164,5			18618					
	K801-06-200					197,4	230,3								
	K801-04-200			15°	46,6	139,8	164,5			18581					
	K801-06-200					197,4	230,3								
	K801-04-200			20°	50,7	139,8	164,5			18542					
	K801-06-200					197,4	230,3								
	K801-04-200			25°	55,0	139,8	164,5			18502					
	K801-06-200					197,4	230,3								
	K801-04-200			30°	59,7	139,8	164,5			18461					
	K801-06-200					197,4	230,3								
	K801-04-200			35°	64,9	139,8	164,5			18419					
	K801-06-200					197,4	230,3								
	K801-04-200			40°	70,7	139,8	164,5			18376					
	K801-06-200					197,4	230,3								
	K801-04-200			45°	77,5	139,8	164,5			18334					
	K801-06-200					197,4	230,3								
	K801-04-200			50°	85,6	139,8	164,5			18292					
	K801-06-200					197,4	230,3								
	K801-04-200			55°	95,9	139,8	164,5			19898					
	K801-06-200					197,4	230,3								
	K801-04-200			60°	110,0	139,8	164,5			22004					
	K801-06-200					197,4	230,3								
	K801-04-200			65°	118,3	139,8	164,5			13478				24030	91
	K801-06-200					197,4	230,3								
K801-04-200	70°	119,9	139,8	164,5	12692	26155	95								
K801-06-200			197,4	230,3											

SUWAKI PODWIESZANE

AERIAL CAM UNITS

K801-04-06-200 (0 ~ 70)

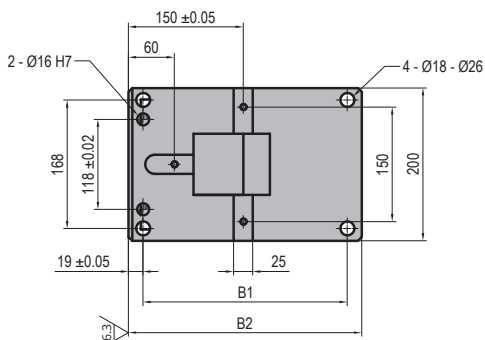

Schemat Suwaka
Cam Diagram

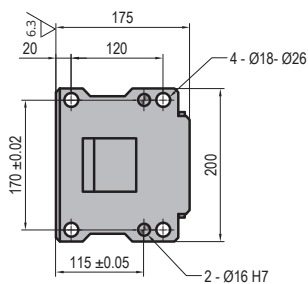
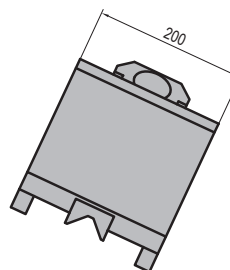
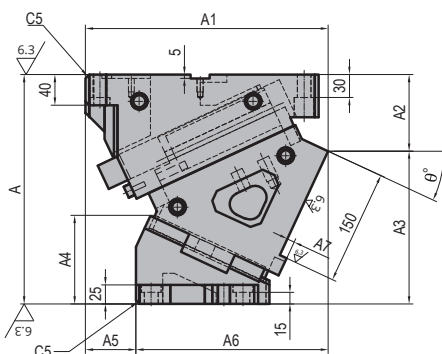
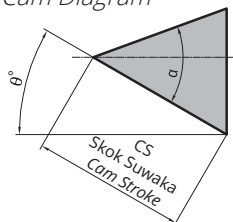

Przykład Zamówienia:
Order Example:
Symbol: K801-06 W=200, θ=5, GS
Symbol Zamówienia / Order Code: K801-06-200-05-GS

Skok Stroke (ST)	Szerokość Width (W)	Wysokość Height (H)	θ	A	A1	A2	A3	A4	A5	A6	A7	B ±0,02	B1	B2	α	Skok Suwaka Cam Stroke (CS)	
Długi Long	200	150	0°	300,00	291,00	67,00	233,00	61,00	116,00	175,00	10,00	-	232,00	270,00	50°	35,40	
			5°		299,87	75,71	224,29	67,80	108,00	191,87		-	242,00	280,00		39,00	
			10°		307,34	82,22	217,78	77,90	99,00	208,34		-	252,00	290,00		42,80	
			15°		312,43	88,49	211,51	89,40	88,00	224,43		-	257,00	295,00		46,60	
			20°		316,16	94,48	205,52	102,00	77,00	239,16		-	262,00	300,00		50,70	
			25°		317,55	100,18	199,82	115,80	66,00	251,55		-	267,00	305,00		55,00	
			30°		318,63	108,55	191,45	127,50	52,00	266,63		-	-	-		59,70	
			35°		315,43	117,57	182,43	139,00	34,00	281,43		-	-	-		64,90	
			40°		309,99	128,21	171,79	149,40	14,00	295,99		-	-	-		70,70	
			45°		303,33	147,45	152,55	151,70	4,00	307,33		-	-	-		77,50	
			50°		295,50	157,27	142,73	163,50	23,00	318,50		-	272,00	310,00		85,60	
			55°		292,25	161,13	138,87	169,50	42,00	334,25		-	-	-		55°	95,90
			60°		286,45	161,36	138,64	172,50	54,00	340,45		18,00	-	-		60°	110,00
			65°		287,31	165,70	134,30	177,00	69,00	356,31		27,00	-	-		65°	118,30
70°	287,62	176,95	123,05	175,80	88,00	375,62	35,00	-	-	70°	119,90						

