



**Materiał / Material**

1. CK45  
Twardość / Hardness  
58 ÷ 60 HRC
2. CK45  
Twardość / Hardness  
54 ÷ 56 HRC
3. CK45  
\*Twardość / Hardness  
\*58 ÷ 60 HRC
4. Sprężyna / Spring
5. Sprężyna / Spring

**Jak zamówić / How to order**

Symbol: **M301-14-180**

Inne wymiary na żądanie  
Other dimensions on demand

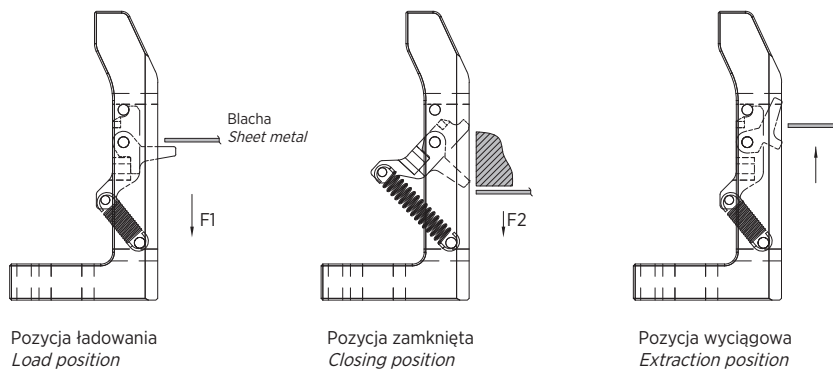
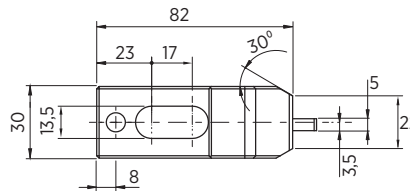
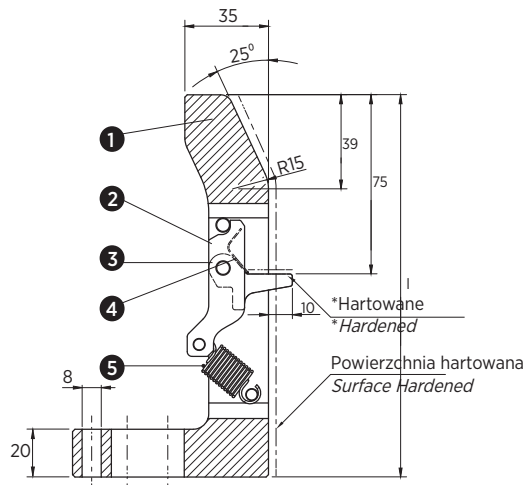

Symbol	l	F1 (N)	F2 (N)
M301-14-160	160	5,90	18,50
M301-14-1601		10,00	30,00
M301-14-1602		22,00	65,00
M301-14-170	170	5,90	18,50
M301-14-1701		10,00	30,00
M301-14-1702		22,00	65,00
M301-14-180	180	5,90	18,50
M301-14-1801		10,00	30,00
M301-14-1802		22,00	65,00
M301-14-190	190	5,90	18,50
M301-14-1901		10,00	30,00
M301-14-1902		22,00	65,00
M301-14-200	200	5,90	18,50
M301-14-2001		10,00	30,00
M301-14-2002		22,00	65,00