

ŁAPY DOCISKOWE ODSADZONE

CRANKED CLAMPS

DIN 6316

S260

Materiał / Material

Łapa S260 jest produkowana poprzez frezowanie bloku stali (nie przez zaginanie). Stal hartowana malowana R>700N/mm²

The S260 clamp is produced by milling a steel block (it is not produced by bending). Hardened painted steel R>700N/mm²

Jak zamówić / How to order

Symbol: S260.26200

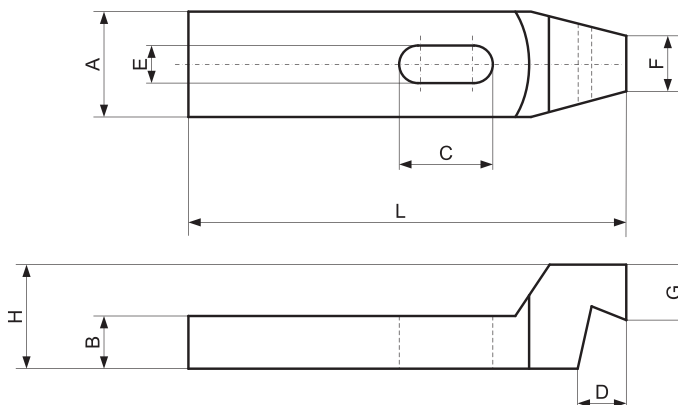

Symbol	A	B	L	C	E	D	F	G	H	Śruba Screw	Waga Weight (g)
S260.14125	40	20	125	30	14	20	20	23	40	12-14	750
S260.18160	50	25	160	40	18	25	25	28	50	16-18	1510
S260.18200	50	25	200	60	18	25	25	28	50	16-18	1790
S260.22160	60	30	160	40	22	30	30	35	60	20-22	2190
S260.22200	60	30	200	60	22	30	30	35	60	20-22	2700
S260.26200	70	35	200	50	26	35	35	38	70	24	3660
S260.26250	70	35	250	75	26	35	35	38	70	24	4560

ŁAPY DOCISKOWE WIDLASTE

FORKED CLAMPS WITH BEVEL

DIN 6315B

S270

Materiał / Material

Łapa S270 jest produkowana poprzez frezowanie bloku stali (nie przez zaginanie). Stal hartowana malowana R>600N/mm²

The S270 clamp is produced by milling a steel block (it is not produced by bending). Hardened painted steel R>600N/mm²

Jak zamówić / How to order

Symbol: S270.26200

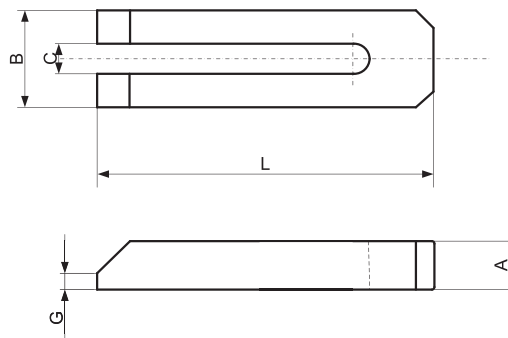

Symbol	A	B	L	C	G	Śruba Screw	Waga Weight (g)
S270.07060	12	20	60	7	3	6	70
S270.09080	15	25	80	9	4	8	150
S270.11100	20	30	100	11	5	10	270
S270.14125	25	40	125	14	6	12-14	590
S270.14160	25	40	160	14	6	12-14	760
S270.14200	25	40	200	14	6	12-14	970
S270.18160	30	50	160	18	8	16-18	1160
S270.18200	30	50	200	18	8	16-18	1400
S270.18250	40	50	250	18	10	16-18	2330
S270.22200	40	50	200	22	10	20-22	1700
S270.22250	40	60	250	22	10	20-22	2880
S270.22315	40	60	315	22	10	20-22	3530
S270.26200	40	70	200	26	10	24	2680
S270.26250	40	70	250	26	10	24	3370
S270.26315	40	70	315	26	10	24	4220
S270.34250	50	80	250	34	12	27-30	4480
S270.34315	50	80	315	34	12	27-30	5600
S270.34400	50	80	400	34	12	27-30	7150
S270.40400	60	100	400	40	12	36	11700
S270.40600	60	100	600	40	12	36	17300