

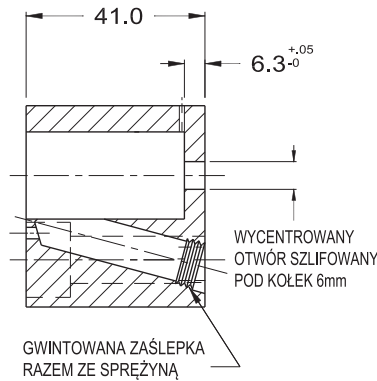

OPRAWKI BALL LOCK

MOELLER™
PRECISION TOOL

MINI TRUE SET

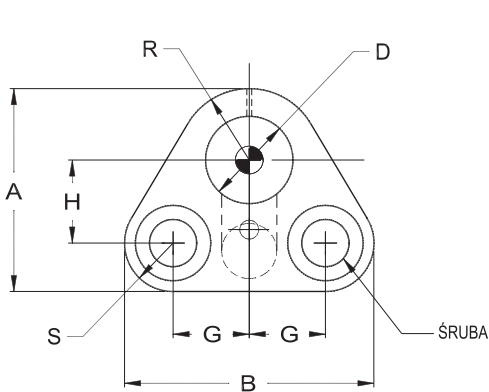

Manufactured under Patent No.'s 0351395, 5357835

AKCESORIA ORAZ PŁYTKI, ZOBACZ
NA STRONACH G60-G61.

Kompletne projekty oraz pliki CAD odwiedź WWW.MOELLERMCAD.COM

Wysokie obciążenia

NUMER KATALOGOWY	D	A	B	G	H	R	S	ROZMIAR ŚRUBY
MRM 10	10	37.8	40.6	11.1	19.0	9.5	9.2	M8
MRM 13	13	40.3	47.6	14.3	19.0	11.7	9.5	M8
MRM 16	16	42.1	50.8	15.9	19.0	13.5	9.5	M8
MRM 20	20	46.5	57.1	17.5	19.0	16.4	11.1	M10
MRM 25	25	56.5	65.1	19.8	23.8	20.0	12.7	M12
MRM 32	32	58.2	64.0	19.8	23.8	22.2	12.2	M12
MRM 40	40	67.3	76.2	24.0	27.0	26.0	14.3	M12

PODKŁADKI

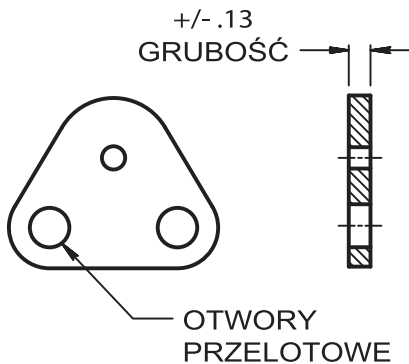

Dostępne Grubości	Symbol Grubości
3.0	030
6.0	060
10.0	100
13.0	130

Symbol zamówienia
MAM 10-
MAM 13-
MAM 16-
MAM 20-
MAM 25-
MAM 32-
MAM 40-

UMIEŚĆ SYMBOL GRUBOŚCI

PRZYKŁAD ZAMÓWIENIA
MAM 16-060