

# OPRAWKA I AKCESORIA

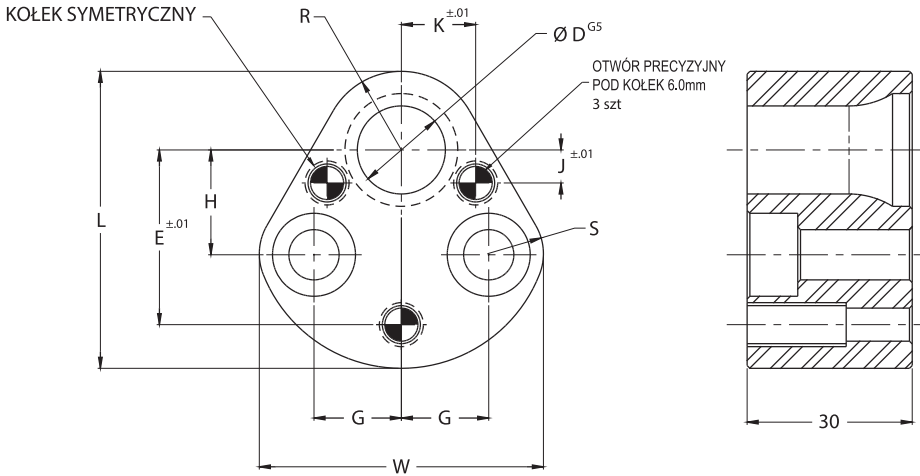

NUMER CZĘŚCI	D	L	W	R	H	J	K	S	G	E	ROZMIAR ŚRUBY
XMRT 010	10	44.32	39.75	9.5	19.05	7.5	9.0	12.65	11.1	26.925	M8
XMRT 013	13	50.67	48.13	12.7	19.05	6.5	12.0	9.47	14.3	29.970	M8
XMRT 016	16	53.85	51.64	14.2	19.05	6.0	13.5	9.47	15.9	31.750	M8
XMRT 020	20	60.20	58.00	17.4	19.05	5.0	16.5	12.62	17.5	33.530	M10

## TULEJKI DO STEPLI Z SZYJKĄ BUTELKI

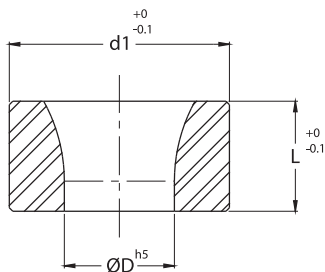

NUMER CZĘŚCI	D	d1	L
XMAQ 005	5	9	7
XMAQ 006	6	11	7
XMAQ 008	8	13	8
XMAQ 010	10	16	9
XMAQ 013	13	19	9
XMAQ 016	16	22	9
XMAQ 020	20	27	10

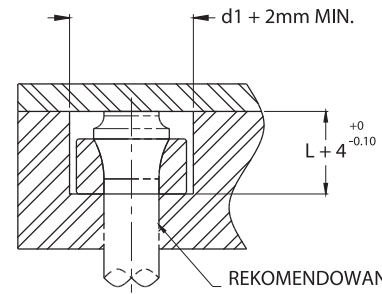

REKOMENDOWANE WYMIARY GNIAZDA POD TULEJKĘ DO STEPLI Z ŁBEM SZYJKI BUTELKI

REKOMENDOWANA TOLERANCJA OTWORU POD STEPEL "G5"

## FREZY DO OTWORÓW POD STEPLE Z SZYJKĄ BUTELKI

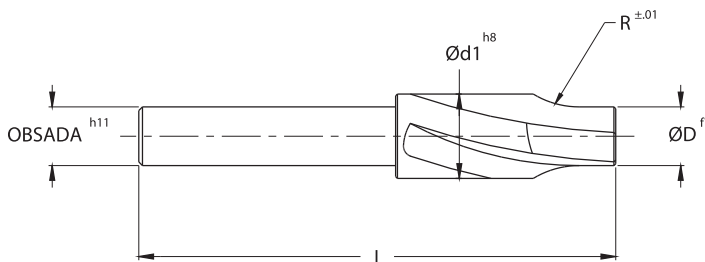

TYP KATALOGOWY	D	d1	R	OBSADA FREZU	L
XMAK 005	5	7.4	10	7.4	71
XMAK 006	6	9.5	10	9.5	71
XMAK 008	8	11.5	12	11.5	71
XMAK 010	10	14.5	15	13	71
XMAK 013	13	17.5	15	13	71
XMAK 016	16	20.5	15	13	71
XMAK 020	20	25.5	15	16	71